

391-11

FRANKLIN
INSTITUTE
LIBRARY

010
JUL 2

Designing Methods

Reinforced Concrete Construction

VOL. 1

OCTOBER, 1908

No. 5

RETAINING WALLS

—OF THE—

CANTILEVER AND BUTTRESS TYPES

Discussion of the special problems met with in the design of retaining walls, with a brief discussion of the subject of earth pressures.

Detailed designs of cantilever wall to retain earth fill for both horizontal surface and with surcharge. Detailed design of buttress type of wall, surface of fill horizontal.

BULLETIN NO 6, VOL. 1, WILL CONTAIN

Detailed design of rectangular
reservoir.

THIS NUMBER WILL BE PUBLISHED IN DECEMBER.

EXPANDED METAL AND CORRUGATED BAR CO.

Suite 925 to 937, Frisco Building

SAINT LOUIS

FRANKLIN
INSTITUTE
LIBRARY

COPYRIGHT, 1908,
BY
EXPANDED METAL AND CORRUGATED BAR COMPANY

RETAINING WALLS FOR EARTH.

A reinforced concrete retaining wall can be built at less cost than a gravity section of equal stability, under practically all conditions. Moreover the amount of saving that may be effected by the adoption of a reinforced concrete design increases with the height of the wall; comparative estimates on actual designs would show a saving of 20 to 25% on walls 30 to 40 feet high.

The dimensions of a gravity section or "heavy masonry" retaining wall are determined, not from a consideration of the strength of the material used in resisting tensile or compressive stresses, but by making it of such size that the weight alone enables it to resist the overturning moment of the backing. The usual condition imposed is that the resultant of the forces acting on the section shall pass through the middle third of the base, thus avoiding any possibility of tension on the inner face, but in most cases causing very heavy soil pressure under the toe. This pressure, which in the case of a gravity section, may exceed the safe bearing power of the soil—necessitating the use of piling—can very often be brought within the allowable amount by the adoption of a reinforced concrete design. When piling must be used in any event, a large saving in the cost of the foundation results from the use of a reinforced concrete wall.

A reinforced concrete retaining wall may be described as a section which derives its stability (against overturning) mainly from that part of the fill which rests upon the base; its structural integrity depending upon its ability to develop tensile as well as compressive and shearing stresses. The dimensions are not determined from a consideration of the weight of the wall as in gravity sections, but from considerations of strength as a structural material.

A reinforced concrete retaining wall will then be in almost all cases of less cost than a gravity type of wall; the total pressure on the foundation will be less, and the maximum soil pressure at the toe may be kept within required limits, owing to the possibility of extending the base. Differently expressed this means that with a reinforced concrete wall a smaller and more uniform soil pressure is produced—a most desirable condition. Owing to the small sections used in a reinforced concrete design, it is practicable to provide against temperature and shrinkage cracks by means of longitudinal reinforcement without resorting to expansion joints.

EARTH PRESSURE AGAINST RETAINING WALLS.

It is not proposed here to discuss the various theories of earth pressure against retaining walls. The active pressure exerted by the fill varies with the material, its compactness, the percentage of contained moisture, etc. If no provision for drainage is made, and there is an opportunity for water to collect behind the wall the pressure may have any value up to hydrostatic pressure.

Experience has shown that masonry walls of the gravity type will be stable under all conditions usually met with when the width of the base is made $\frac{1}{10}$ of the height. Reinforced concrete retaining walls, therefore, should be so designed that the stability against overturning will be at least as great as that of a solid masonry wall the base of which is $\frac{1}{10}$ of the height. It is therefore recommended that for ordinary fills (horizontal surface), where the material is not likely to become saturated, that the design be based on an active horizontal pressure, the intensity of which at any point is $\frac{1}{3}$ of the vertical intensity at that point. A wall designed on this basis will have a slightly greater factor of stability than the gravity section referred to.

For convenient reference Rankine's formulæ for earth pressures are given, as they are in general use. It is to be noted that for a horizontal surface and $\phi = 30^\circ$, the intensity of the horizontal pressure, becomes $\frac{1}{3}$ the vertical.

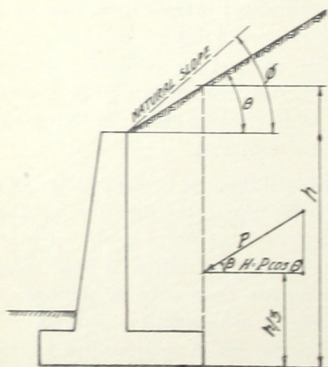

Fig. 1.

Let Fig. 1 represent a retaining wall, the surface of the fill making an angle θ with the horizontal. The symbols may be defined as follows:

w = weight of fill per cubic foot.

P = the resultant pressure corresponding to a depth of fill h .

$P = H$, when θ is equal to zero.

θ = angle with the horizontal made by the surface of fill.

ϕ = angle of repose, or natural slope of the material constituting the fill.

p = intensity of the horizontal pressure at any depth, in pounds per sq. foot.

Then :

$$P = \left(\frac{wh^2}{2} \cos \theta \times \frac{\cos \theta - \sqrt{\cos^2 \theta - \cos^2 \phi}}{\cos \theta + \sqrt{\cos^2 \theta - \cos^2 \phi}} \right) \dots \dots (1)$$

When $\theta = \phi$, which is the usual value in surcharge design we have :

$$P = \frac{wh^2}{2} \cos \phi \dots \dots \dots (2)$$

If the surface is horizontal, θ equals zero, and we have :

$$P = \frac{wh^2}{2} \times \frac{1 - \sin \phi}{1 + \sin \phi} = H \dots \dots \dots (3)$$

In all cases

$$H = P \cos \theta \dots \dots \dots (4)$$

It may be noted that the formulæ take no account of such cohesion as may exist between the particles of the fill and that equation 3 will give the pressure due to a liquid if ϕ is made equal to zero, the equation reducing to the form $P = \frac{1}{2} wh^2$.

Since the intensity of the horizontal pressure is assumed to increase uniformly with the depth the resultant, P , will act at a distance $\frac{1}{3} h$ from the base of the wall.

For ordinary fills, where the material is not likely to become saturated, ϕ may be assumed to have a value of 30° ; substituting this value in equation 3 we have for a horizontal surface

$$P = H = \frac{wh^2}{6} \dots \dots \dots (5)$$

$$\text{and } p = \frac{wh}{3} \dots \dots \dots (6)$$

Equations 5 and 6 should be used for earth fills when the surface of the fill is horizontal; these values it will be noted agree with those previously recommended.

Superimposed Loads—A uniformly distributed load, covering the entire surface of the fill will be assumed to exert a uniform horizontal pressure, the intensity of which is $\frac{1}{3}$ of the vertical, regardless of the depth.

The following table gives the intensity of the horizontal pressure, p , at any depth, h , the total pressure H , above the section considered and the overturning moment, M , in inch lbs., at the section $A-B$:

HORIZONTAL SURFACE.

$w=100$ lbs.

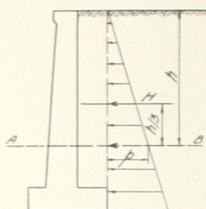

TABLE I.

SURCHARGE, $\theta=30^\circ$

$w=100$ lbs.

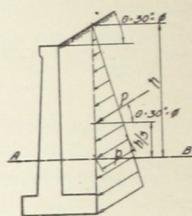

TABLE II.

h	$p=\frac{1}{2}wh$	$H=P=\frac{1}{6}wh^2$	Overturning Moment $M=\frac{1}{12}wh^3 \times 12$	h	$p \cos \theta = \frac{3}{4}wh$	$H=P \cos \theta = \frac{3}{8}wh^2$	Overturning Moment $M=\frac{1}{6}wh^3 \times 12$
feet.	pounds.	pounds.	inch pounds.	feet.	pounds.	pounds.	inch pounds.
1	33	17	67	1	75	38	150
2	67	67	533	2	150	150	1200
3	100	150	1800	3	225	338	4050
4	133	267	4267	4	300	600	9600
5	167	417	8333	5	375	938	18750
6	200	600	14400	6	450	1350	32400
7	233	817	22867	7	525	1838	51450
8	267	1067	34133	8	600	2400	76800
9	300	1350	48600	9	675	3038	109350
10	333	1667	66667	10	750	3750	150000
11	367	2017	88733	11	825	4538	199650
12	400	2400	115200	12	900	5400	259200
13	433	2817	146467	13	975	6338	329550
14	467	3267	182933	14	1050	7350	411600
15	500	3750	225000	15	1125	8438	506250
16	533	4267	273067	16	1200	9600	614400
17	567	4817	327533	17	1275	10838	736950
18	600	5400	388800	18	1350	12150	874800
19	633	6017	457267	19	1425	13538	1028850
20	667	6667	533333	20	1500	15000	1200000
21	700	7350	617400	21	1575	16538	1389150
22	733	8067	709867	22	1650	18150	1597200
23	767	8817	811133	23	1725	19838	1825050
24	800	9600	921600	24	1800	21600	2073600
25	833	10417	1041667	25	1875	23438	2343750
26	867	11267	1171733	26	1950	25350	2636400
27	900	12150	1312200	27	2025	27338	2952450
28	933	13067	1463467	28	2100	29400	3292800
29	967	14017	1625933	29	2175	31538	3658350
30	1000	15000	1800000	30	2250	33750	4050000

NOTES ON DESIGN.

In the design of retaining walls it is necessary to investigate the stability of the structure, not only against overturning but also against sliding upon its base. To prevent sliding the total pressure upon the foundation multiplied by the co-efficient of friction of concrete upon the soil, must be greater than the horizontal thrust of the fill. It is good practice to provide a projection or toe extending into the foundation to assist in preventing such movement.

The maximum soil pressure at the toe of the retaining wall should be computed in all cases, as it is very often the determining factor in the design of the base.

In the design and construction of retaining walls, provision should be made for adequate drainage. This is an important feature as the development of an hydraulic head back of the wall, might result in its failure.

Provision should be made in all retaining wall work, against the development of shrinkage or temperature cracks. On account of the small sections required in a reinforced concrete design, it is practicable to prevent the development of such cracks by the use of longitudinal reinforcement. Some longitudinal reinforcement should be used even if expansion joints are provided.

It is usually considered that about $\frac{1}{10}\%$ of reinforcement will be sufficient to prevent cracks, using high elastic limit steel.

Retaining walls of the cantilever type will generally be found economical up to heights of 18 feet; for higher walls the buttress type should be used.

The following diagrams, Figures 2 and 3, show the forces acting upon a retaining wall which we will consider in the design :

W_c = weight of section of wall one foot long ; the line of action passing through the center of gravity of the cross section.

W_e = weight of earth, per lineal foot, resting on base of wall ; the line of action passing through center of gravity of the figure C, D, E, F.

p_2 = soil pressure at toe, lbs. per sq. foot.

p_3 = soil pressure at the heel, in lbs. per sq. foot.

R = resultant of the earth pressure and $(W_c + W_e)$.

Other symbols as previously defined.

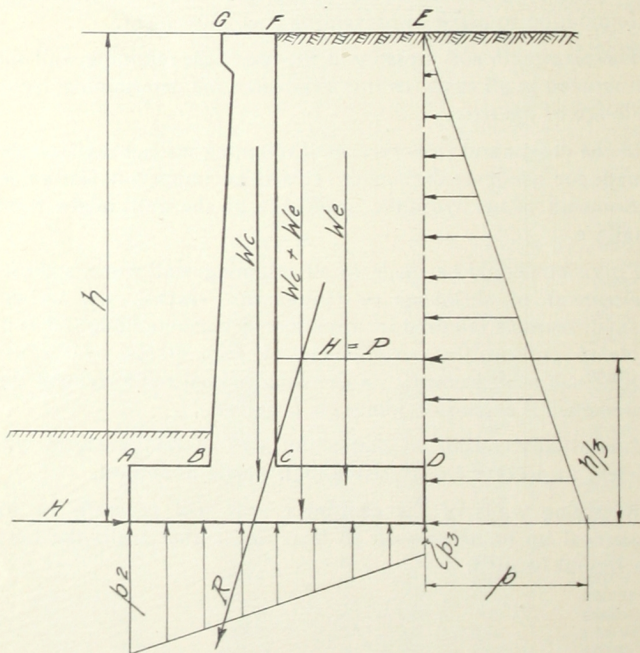

Figure 2.

Diagram showing forces acting upon a retaining wall, surface of fill horizontal.

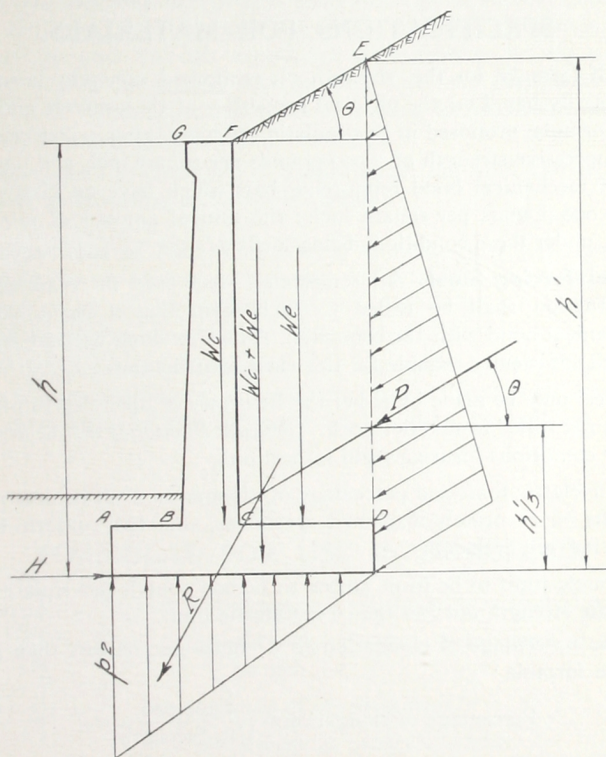

Figure 3.

Diagram showing forces acting upon a retaining wall, surface of fill not horizontal.

SPECIFICATIONS FOR MATERIALS.

All formulæ for the strength of reinforced concrete beams are necessarily based on the physical properties of the concrete and steel. The formulæ proposed in this bulletin are based upon a concrete with a compressive strength of 2,000 pounds per square inch and upon the use of mechanical bond reinforcing bars which have an elastic limit of 50,000 pounds per square inch; the critical amount of reinforcement, under these conditions being .0085 *bd*.

Reinforcing Steel—All reinforcing steel used in retaining wall construction shall be rolled to such form that it has a positive mechanical bond with the concrete. Adhesive bond will not be considered sufficiently reliable for this class of structures.

Steel may be made by either the Bessemer or open-hearth process; bars to be rolled from billet stock. Re-rolled material will be accepted under conditions insuring rigid inspection.

The elastic limit and percentage of elongation shall be determined by tests on accurately-machined specimens, and shall conform to the following requirements:

Elastic limit to be from 50,000 to 60,000 pounds per square inch, ultimate strength not less than $1\frac{1}{2} \times$ elastic limit.

The percentage of elongation in 8" must not be less than given by the formula:

$$\text{Percentage of elongation} = \frac{1,400,000}{\text{Ult. Strength}} - 5.$$

Bending Test—Bars as rolled shall bend cold, 90 degrees, to a radius equal to three times the least diameter of the specimen, without sign of fracture.

Cement—Only Portland cement conforming to the requirements of the specifications adopted by the American Society for Testing Materials, June 14, 1904, shall be used.

Sand—Sand to be clean and coarse, and free from organic matter; a graded sand, with coarse grains predominating, is to be preferred.

Coarse Aggregate—Broken stone to be hard, durable limestone, or its equivalent, free from dust and foreign materials; maximum-sized particles to pass through a one-inch ring; fines to be removed by passing over a one-quarter inch screen. The fines may replace part of the sand. Under special conditions making for uniformity crusher run may be used, but this is not desirable.

Gravel shall be clean and of graded sizes; the sand carried to be removed by screening as for broken stone.

Proportions of Mix—Concrete for wall, base, and buttresses to be mixed in the proportion of one part cement to six parts aggregate; proportions by volume taking one bag containing not less than 94 pounds of cement, equal to one cubic foot of cement.

The proportions of fine and coarse aggregate used shall be chosen so as to give a concrete of maximum density; in no case, however, may the amount of fine aggregate be less than 50 per cent of the coarse.

FORMULAE FOR USE IN DESIGNING.

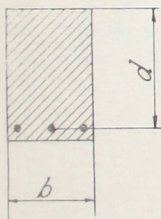

Let M = moment of resistance of section in inch lbs.

M_o = ultimate moment of resistance of section in inch lbs.

q = area of reinforcement.

p = percentage of steel = $q \div bd$.

F = elastic limit of steel = 50,000 lbs.

All dimensions as shown, in inches, and stresses in lbs. per sq. in.

Then we have for rectangular beams:

$$M_o = 370 bd^2 \text{ for } q = .0085 bd \dots\dots\dots (7)$$

and for various percentages;

$$M_o = .86 Fp bd^2 = .86 \times 50,000 \times p bd^2 \dots\dots\dots (8)$$

$$= 43,000 p bd^2, \text{ using high elastic limit corrugated bars.}$$

(For complete discussion of these formulæ, see May and June bulletins)

WORKING STRESSES.

If it is desired to design for working stresses in the steel, use the formula:

$$M = sq \times .86 d, \text{ where } s = \text{unit stress in the steel. . (9)}$$

REMARKS ON THE APPLICATION OF THE FORMULAE.

In retaining wall design it will often be found that the section required to resist the bending moment, as determined by formula 7, is smaller than would be desirable to use in heavy work. In this case the value of "d" may be assumed, and the amount of reinforcement required determined by means of equation 8.

Equation 8 should also be used in the design of buttresses, as there is more or less T-beam action. The amount of reinforcement used, however, should not exceed 2% of the cross section of the buttress.

It is to be noted that equations 7 and 8 give the ultimate or breaking strength of the structure, and in applying them the actual moments must first be multiplied by the factor of safety.

CANTILEVER WALLS.

The two examples following illustrate the methods of design advocated:

Problem 1—Design a cantilever wall, 16'-0" high, to retain an earth fill weighing 100 lbs. per cubic foot; surface of fill horizontal, the value of ϕ to be taken as 30° .

Maximum allowable soil pressure 3,000 lbs. per square foot.

We will assume the section shown herewith and investigate its stability and strength:

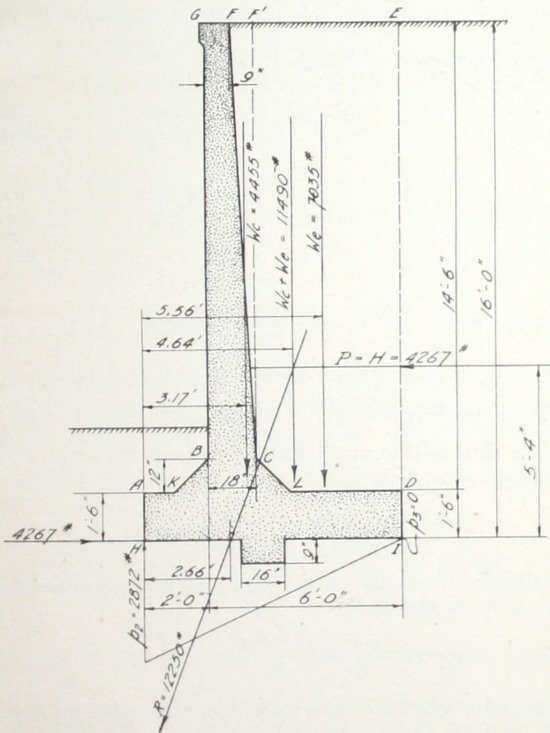

To determine the position of the center of gravity of the concrete section and of the earth prism take moments about the point "A."

Center of Gravity of Wall—

SECTION CONSIDERED.	AREA IN SQ. FT.	MOMENT ARM.	AREA MOMENT.
<i>ADIH</i>	12.0	4.00	48.0
<i>KBCL</i>	2.5	2.75	6.9
<i>BCFG</i>	15.2	2.58	39.2
Totals	29.7	94.1

$$\text{Distance from "A" to } cg = \frac{94.1}{29.7} = 3.17 \text{ ft.}$$

$$\text{Weight of wall per lineal foot} = 29.7 \times 150 = 4445 \text{ lbs.} = W_c.$$

$$\text{Static moment about "A"} = 4445 \times 3.17 = 14110 \text{ ft. lbs.}$$

Center of Gravity of Earth Prism—

SECTION CONSIDERED.	AREA IN SQ. FT.	MOMENT ARM.	AREA MOMENT.
<i>CFF'</i>	5.1	3.25	16.6
<i>CF'ED</i>	65.25	5.75	375.2
Totals.....	70.35	391.8

$$\text{Distance from "A" to } cg = \frac{391.8}{70.35} = 5.56 \text{ ft.}$$

$$\text{Weight of earth prism per lineal foot} = 70.35 \times 100 = 7035 = W_e.$$

$$\text{Static moment about "A"} = 7035 \times 5.56 = 39180 \text{ ft. lbs.}$$

To obtain the position of the resultant divide the sum of the static moments by the total weight :

$$\frac{14110 + 39180}{4445 + 7035} = \frac{53290}{11480} = 4.64 \text{ ft.}$$

The horizontal thrust, *H*, on the wall may be determined by means of formula 5.

$$P = H = \frac{wh^2}{6} = \frac{110 \times 16^2}{6} = 4267 \text{ lbs.}$$

(The pressure might have been taken from the table on page 146).

This thrust is assumed to be concentrated at a point 5'-4" above the base. Combining this force with the force $W_c + W_e$ we obtain the final resultant *R*.

$$R = \sqrt{(4267^2 + 11490^2)} = 12250 \text{ lbs.}$$

The tangent of the angle which the resultant makes with the vertical is $\frac{4267}{11490} = .372$, and R would cut the base at a distance, $5.33 \times .372 = 1.98$ ft. from the line $W_o + W_e$, or 2.66 ft. from the edge $A-H$.

Since the resultant R passes through the third point the soil pressure at the heel is zero, and that at the toe is twice the average.

$$\text{Average soil pressure} = \frac{11490}{8} = 1436 \text{ lbs. per sq. ft.}$$

$$\text{Maximum soil pressure} = p_2 = 2 \times 1436 = 2872 \text{ lbs. per sq. ft.}$$

Stability Against Sliding—The total horizontal thrust = 4267 lbs. Assuming that the foundation is good clay the coefficient of friction between the concrete and the soil may be taken as .50. The frictional resistance to horizontal displacement would then equal $11490 \times .5 = 5745$ lbs. It is desirable, however, to have a projection on the base as shown in the drawing as the coefficient of friction may be as small as .33 should the footing become wet.

The earth fill in front of the wall assists to a slight extent in resisting sliding, but its action is not positive, and should not be included in the design.

REINFORCING STEEL.

Having assured ourselves of the stability of the section, when acted upon by the assumed forces, it will be necessary to examine its structural integrity and provide reinforcing steel where required.

The bending moment, per foot of length, in the face wall at the plane $A-D$ is equal to

$$\frac{100 \times 14.5^2}{6} \times \frac{14.5}{3} = \frac{100}{18} \times 14.5^3 = 16900 \text{ ft. lbs.}$$

$$= 202800 \text{ inch lbs.}$$

Neglecting the small fillets the effective depth of the beam, d , may be taken as 16".

We will base the design on the ultimate strength of the section using a factor of safety of 3, and determine the amount of reinforcement required by means of formula 8.

$$M_o = 3 \times 202800 = 608400 = 43000 pbd^2.$$

$b=12''$ and $d=16''$, substituting these values in the equation we have $\phi=.0046$.

$$q=16 \times 12 \times .0046=.88 \text{ sq. in. per foot of wall.}$$

Use $\frac{3}{4}''$ corrugated rounds, spaced $6''$ on centers.

It will not be necessary to carry this amount of reinforcement to the top of the wall, as the bending moments decrease rapidly toward the surface of the fill. The bending moment at a point $10'0''$ below the surface is 66,667 inch pounds.

$$M_o=3 \times 66,667=200,000 \text{ in. lbs. (ult.)}$$

The thickness of the wall at this point is $15.6''$, $d=13.6''$. The amount of metal required, $q,=.34$ sq. in. per foot of wall, which would indicate that one-half of the reinforcing bars may be stopped off at this point.

It is necessary in all cantilever designs to investigate the anchorage of the vertical bars in the base. If the length of imbedment is not sufficient the bars may pull out, due to the shearing of the concrete around them. Using round corrugated bars a length of imbedment of 25 diameters will insure sufficient shearing strength. The vertical bars will accordingly be extended into the projection on the base as shown on detailed drawing, page 158.

Design of Base—That part of the base back of the wall will be made sufficiently strong to lift the fill resting upon it in addition to its own weight. We will determine the bending moment on a vertical plane through the point *C*.

Taking moments about *C*, we have:

$$\text{Moment due to fill} = 7035 \times 2.06 = 14492 \text{ ft. lbs.}$$

$$\text{Moment due to base} = 1012 \times 2.25 = \underline{2277} \quad ''$$

$$16769 \text{ ft. lbs.}$$

$$= 201228 \text{ in. lbs.}$$

The effective depth d , is $16''$, and the amount of reinforcement required is .88 sq. in. per lineal foot of wall.

Use $\frac{3}{4}''$ corrugated rounds, $6'-6''$ long, spaced $6''$ on centers in the top of the slab.

In the design of the toe, since the overhang is small, we will assume a uniform upward pressure of 2872 lbs. per sq. foot. The footing weighs 225 lbs. per sq. foot, and the effective upward pressure is $2872-225=2647$ lbs.

Taking moments about *B*:

$$M = (2 \times 2647) \times 1 = 5294 \text{ ft. lbs.} = 63530 \text{ in. lbs.}$$

$$M_o = 3 \times 63530 = 190590 \text{ in. lbs., and applying equation 8.}$$

$$q = \frac{190590}{43000 \times 16} = .276 \text{ sq. in.}$$

Use $\frac{5}{8}$ " corrugated rounds 4'-0" long, spaced 12" on centers.

It is desirable to fillet the corners, where the face wall joins the base, providing sufficient reinforcement in the rear fillet to carry the bending moment. Owing to the depth available for beam action $\frac{3}{4}$ " corrugated rounds, spaced 12" on centers will be sufficient.

Longitudinal Reinforcement—As before stated the amount of longitudinal reinforcement required in the face wall is dependent upon the particular conditions—the position of the wall, its exposure and the probable range of temperature. Some longitudinal reinforcement is necessary in any event in both wall and base. We will use $\frac{1}{2}$ " corrugated rounds spaced 24" cts. in each side of the wall. If it is desired to provide fully for temperature stresses the amount of longitudinal reinforcement, above the grade line should be increased to about .004 of the cross section.

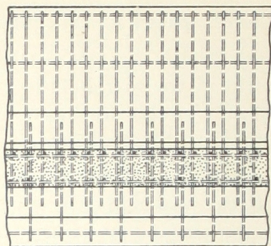
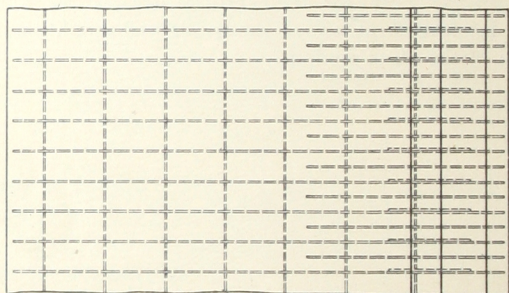
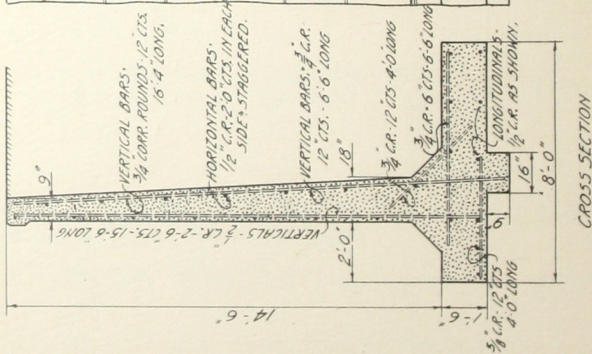

NOTE -
 ALL REINFORCING BARS ARE HIGH
 ELASTIC LIMIT CORRUGATED ROUNDS.

DETAILS.

RETAINING WALL

16'-0" HIGH.
 CANTILEVER TYPE. PROBLEM I.

Problem 2—Design a cantilever wall, 16' 0" high, to retain an earth fill, the surface of which slopes upward at an angle $\theta = \phi =$ angle of repose of the material.

Maximum allowable soil pressure, 5000 lbs per sq. ft.

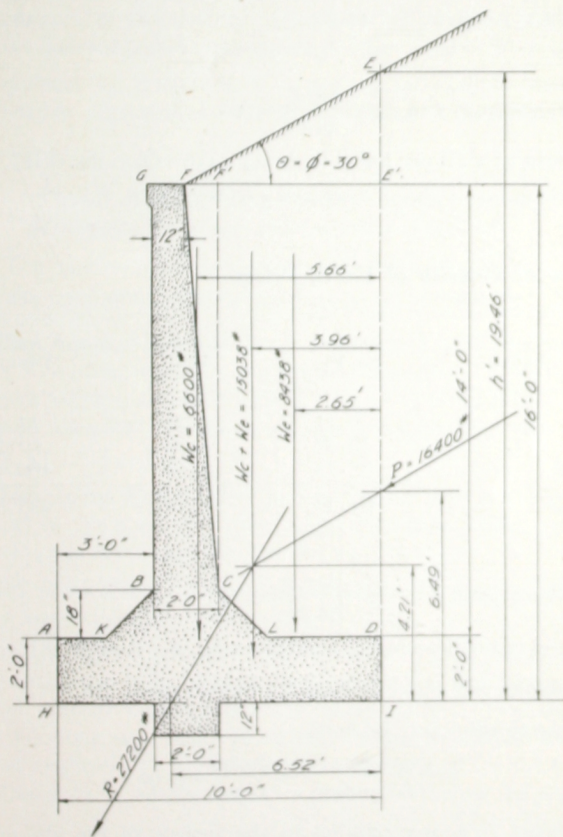

We will determine the position of the center of gravity of the concrete section and of the earth prism by taking moments about the point I.

Center of Gravity of Wall—

SECTION CONSIDERED.	AREA IN SQ. FT.	MOMENT ARM.	AREA MOMENT.
<i>CFCB</i>	18.75	6.22	117.0
<i>BCLK</i>	5.25	6.00	31.5
<i>ADIH</i>	20.00	5.00	100.0
Totals.....	44.00	248.5

$$\text{Distance from } I \text{ to } cg = \frac{248.5}{44.0} = 5.66.$$

Weight of wall per lineal foot = $44 \times 150 = 6600$ lbs. = W_c .

Static moment about $I = 6600 \times 5.66 = 37356$ ft. lbs.

Center of Gravity of Earth Prism—

SECTION CONSIDERED.	AREA IN SQ. FT.	MOMENT ARM.	AREA MOMENT.
<i>FCF'</i>	6.25	5.33	33.3
<i>EFE'</i>	10.38	2.00	20.7
<i>FCLDE</i>	67.75	2.50	169.4
Totals.....	84.38	223.4

$$\text{Distance from } I \text{ to } cg = \frac{223.4}{84.38} = 2.65.$$

Weight of earth prism per lineal foot = $84.38 \times 100 = 8438$ lbs. = W_e .

Static moment about $I = 8438 \times 2.65 = 22350$ ft. lbs.

Distance to resultant, $W_c + W_e$,

$$= \frac{37356 + 22350}{6600 + 8438} = \frac{59706}{15038} = 3.96.$$

The thrust P , acting parallel to the surface of the fill, may be determined by means of formula 2.

$$P = \frac{wh^2}{2} \cos \phi$$

$$= \frac{100 \times 19.46^2}{2} \times .866 = 16400 \text{ lbs.}$$

The force P should be considered as applied on the plane IE , and at a point $\frac{1}{3} h'$ above the base. Combining P and $(W_c + W_s)$ we obtain the resultant $R=27200$ lbs., which cuts the base at a point 6.52 distant from I .

Soil Pressure—The vertical component of $R=23238$ lbs. acting at a point 6.52 from I . The average soil pressure is 2324 lbs.

The maximum pressure at H is obtained as follows:

The moment of the vertical component of R about the middle point of the base $=23238 \times 1.52 = 35400$ ft. lbs.

The moment of resistance of a rectangular section $=M = \frac{1}{6} f b h^2$, where f = stress on extreme fiber, b = width and h = depth of section.

In this case:

$$b = 1'-0'' \text{ and } h = 10'-0''.$$

$$M = 35400 = \frac{1}{6} f \times 100, \text{ from which } f = 2124 \text{ lbs.}$$

The maximum soil pressure $= 2324 + 2124 = 4448$ lbs.

The minimum soil pressure $= 2324 - 2124 = 200$ lbs.

Stability Against Sliding—With a coefficient of friction of $.5$ the resistance to sliding would be $.5 \times 23238 = 11619$ lbs. The total horizontal force tending to move wall is $P \cos \theta = H = 14200$ lbs. It will be necessary therefore to provide a projection extending into the soil as shown.

Reinforcement Required—The bending moment in the wall (per lineal foot) in the plane $B-C$ may be obtained from Table 2, on page 146, which gives $M = 614400$ in. lbs. for an h of $16'-0''$.

At this point $d = 22''$ and the amount of steel required as determined by formula 9, for $s = 16500$, is 1.98 sq. in.

Use $1''$ corrugated squares $6''$ on centers. Table 2 gives the bending moments at various depths from which we can compute the amount of reinforcement required at these points. This operation leads to the conclusion that $\frac{1}{3}$ of the vertical bars should extend to the top of the wall; $\frac{1}{3}$ should extend to within $3'-0''$ of the top, and the remaining $\frac{1}{3}$ be stopped off at a point $7'-0''$ below the top of the wall.

The vertical bars will have sufficient imbedment if extended to the underside of base.

Design of Base—The bending moment on the base in the plane CF' is obtained by taking moments about the point C .

$$\text{Moment due to fill} = 8438 \times 28'' = 236000 \text{ in. lbs.}$$

$$\text{Moment due to base} = 1500 \times 30'' = \underline{45000 \text{ in. lbs.}}$$

$$281000 \text{ in. lbs.}$$

$$d = 22'' \text{ and } q = .90 \text{ sq. in.}$$

Use 1'' corrugated squares 12'' cts.

Diagonal reinforcement will be placed in the rear fillet in sufficient amount to carry the bending moment at that point; the area required is approximately $\frac{1}{2}$ sq. in. per lineal foot of wall—use $\frac{3}{4}$ '' corrugated squares 12'' on cts.

In the design of the toe we will determine the bending moment in the vertical plane through B .

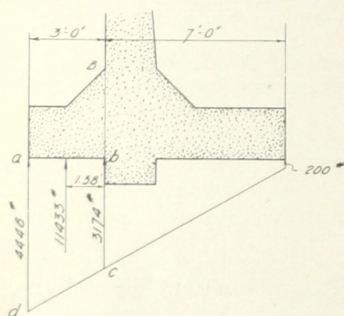

To determine the average pressure on the toe draw the diagram showing soil pressures. The average pressure on the overhang will be $\frac{1}{2} (4448 + 3174) = 3811 \text{ lbs. per sq. ft.}$

The resultant of this reaction will pass through the center of gravity of the trapezoid $abcd$, which is 1.58 ft. from bc .

$$M_o = 1.58 \times (3 \times 3811) \times 12 = 217000 \text{ in. lbs. (ult.)}$$

To resist this moment there will be required .72 sq. in. of steel assuming $d = 22$ inches, and we will use $\frac{7}{8}$ '' corr. squares 12'' cts.

Longitudinal Reinforcement—We will not provide fully for temperature stresses, but will arbitrarily use $\frac{1}{2}$ '' corr. squares spaced 24'' cts. in each face.

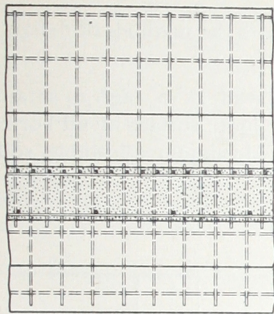
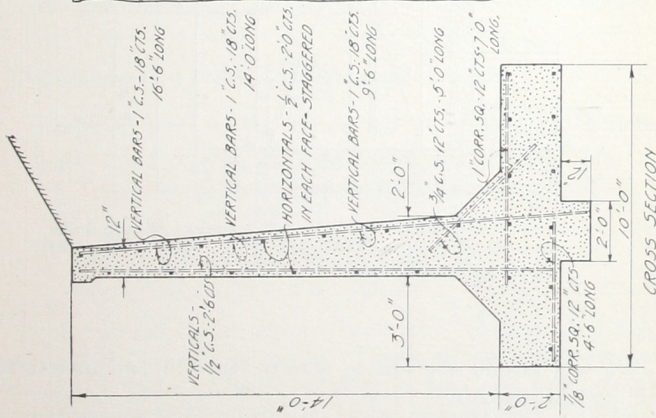

NOTE. ALL REINFORCING BARS ARE HIGH ELASTIC LIMIT CORRUGATED SQUARES.

DETAILS

RETAINING WALL

16'-0" HIGH.

CANTILEVER TYPE. PROBLEM 2.

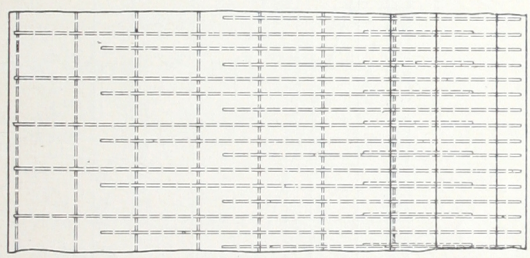

BUTTRESS WALLS.

The following example illustrates the methods of design suggested for this type of retaining wall.

Problem 3—Design a buttress wall 25'-0" high to retain an earth fill weighing 100 pounds per cubic foot; surface of fill horizontal; the value of ϕ to be taken as 30°. Maximum allowable soil pressure 4000 pounds per square foot.

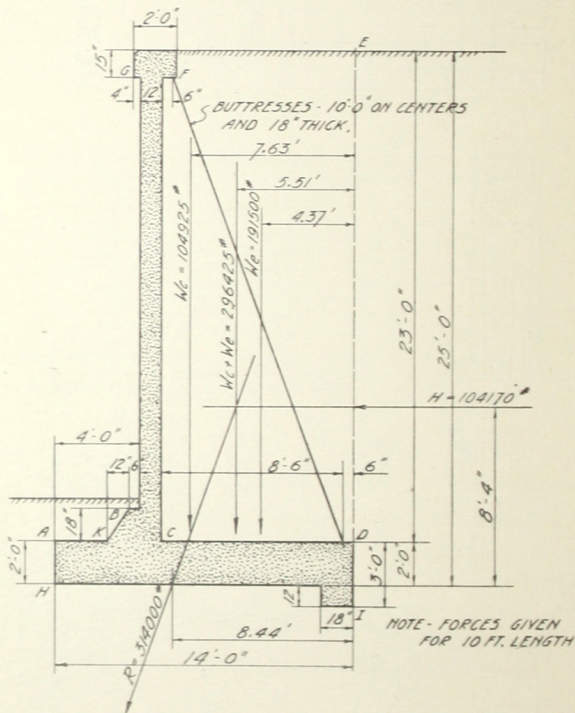

We will assume the section shown herewith, and investigate its stability and strength.

To determine the position of the center of gravity of the wall, we will consider a section 10'-0" long.

Center of Gravity of Wall, moments taken about I—

SECTION CONSIDERED.	VOLUME CU. FT.	MOMENT ARM.	VOLUME MOMENT.
Coping.....	25.0	9.33	233.0
Face Wall.....	217.5	9.50	2065.0
Fillet.....	7.5	10.25	76.7
	7.5	10.83	81.3
Base.....	280.0	7.00	1960.0
Buttress.....	15.0	0.75	11.2
	147.0	6.16	905.0
Totals.....	699.5	5332.2

$$\text{Distance from } I \text{ to } cg = \frac{5332.2}{699.5} = 7.63.$$

$$\text{Weight of ten foot length of wall} = 699.5 \times 150 = 104925 \text{ lbs.}$$

$$\text{Static moment about } I, \text{ for section } 10'-0'' \text{ long} = \\ 104925 \times 7.63 = 800000 \text{ ft. lbs.}$$

Center of Gravity of Earth Prism, moments taken about I—

SECTION CONSIDERED.	VOLUME CU. FT.	MOMENT ARM.	VOLUME MOMENT.
<i>CDEF</i>	1760.0	4.50	7920.0
<i>FED</i>	155.0	3.00	465.0
Totals.....	1915.0	8385.0

$$\text{Distance from } I \text{ to } cg = \frac{8385}{1915} = 4.37.$$

$$\text{Weight of earth per ten feet of wall} = 1915 \times 100 = 191500 \text{ lbs.}$$

$$\text{Static moment about } I, \text{ for section } 10'-0'' \text{ long} = \\ 191500 \times 4.37 = 836000 \text{ ft. lbs.}$$

$$\text{Distance from } I, \text{ to the resultant, } W_c + W_e =$$

$$\frac{800000 + 836000}{104925 + 191500} = \frac{1636000}{296425} = 5.51.$$

The horizontal thrust, H , on a wall 25'-0" high is 10417 lbs. per lineal foot, see Table 1, page 146. The thrust on a ten foot length would be 104170 lbs. Combining this thrust with $W_c + W_e$, we obtain the final resultant, R , which has a value of 314000 lbs., and cuts the base at a distance of 2.93 from the line $W_c + W_e$, or 8.44 from the point I .

Soil Pressure—The weight of the wall and earth prism per lineal foot is 29642 lbs. The average soil pressure equals $\frac{29642}{14} = 2120$ lbs. By the methods illustrated in Problem 2, the maximum soil pressure is found to be 3430 lbs. per sq. ft., and the minimum 810 lbs. per sq. ft.

The maximum and minimum soil pressure may be readily computed by means of the following formula:

$$p = \frac{W}{l} \left(1 \pm \frac{6e}{l} \right), \text{ in which}$$

p = max. or min. soil pressure per sq. ft.

W = total load per lineal foot on soil, in this case $W_e + W_c$.

e = eccentricity of R = distance from center of base to point where resultant cuts under side of base.

l = width of base.

Stability Against Sliding—With a coefficient of friction of .5 the resistance to sliding, per lineal foot of wall, would be $.5 \times 29642 = 14821$ lbs. The horizontal thrust per foot of wall is 10417 lbs. A projection will, however, be provided at the heel, which will serve the additional purpose of giving sufficient anchorage to the buttress reinforcement.

Reinforcement Required—Face wall. The face wall will be designed as a continuous horizontal beam, and reinforcing bars will be placed near the rear face at the abutments and extending to the quarter points of the span. The thickness of the wall is 12" and $d = 10$ ".

Bending moments will be figured by the formula $M = \frac{1}{12} w l^2$.

The following table gives the bending moment and the amount of reinforcement required at various depths:

Depth. ft.	Unit Pressure.	Bend. Mom. $M = \frac{100P}{12} \times 12$	Reinforcement.	
			$q = \frac{M}{.86sd}$	Size and Spacing.
2'	67 lbs.	6700 in. lbs.	.05 sq. in.	$\frac{3}{8}$ " Corr. Rounds, 12"
6'	200 lbs.	20000 in. lbs.	.14 sq. in.	$\frac{1}{2}$ " Corr. Rounds, 12"
10'	333 lbs.	33300 in. lbs.	.23 sq. in.	$\frac{5}{8}$ " Corr. Rounds, 10"
12'	400 lbs.	40000 in. lbs.	.28 sq. in.	$\frac{1}{2}$ " Corr. Rounds, 8"
14'	467 lbs.	46700 in. lbs.	.33 sq. in.	$\frac{3}{8}$ " Corr. Rounds, 7"
16'	533 lbs.	53300 in. lbs.	.38 sq. in.	$\frac{1}{2}$ " Corr. Rounds, 6"
18'	600 lbs.	60000 in. lbs.	.42 sq. in.	$\frac{1}{2}$ " Corr. Rounds, 5 $\frac{1}{2}$ "
20'	667 lbs.	66700 in. lbs.	.47 sq. in.	$\frac{1}{2}$ " Corr. Rounds, 5"
22'	733 lbs.	73300 in. lbs.	.52 sq. in.	$\frac{1}{2}$ " Corr. Rounds, 4 $\frac{1}{2}$ "

Vertical bars in front face = $\frac{1}{2}$ " corr. rounds = 2'-0" on centers.

Base—That part of the base back of the face wall will be designed as a continuous horizontal beam, and made strong enough to lift the earth resting upon it as well as its own weight. It must also be designed to resist the upward reaction of the earth when this exceeds the weight of the materials above the section considered.

Longitudinal reinforcement in bottom of slab, in rear of face wall. Owing to the continuous action moments will be figured on the basis $\frac{1}{12}wl^2$, and top reinforcement will be provided extending to the quarter points. The load per sq. foot is 2600 lbs. For a section 12" wide,

$$M = \frac{1}{12}wl^2 = \frac{1}{12} \times 2600 \times 10^2 \times 12 = 260000 \text{ in. lbs.}$$

$d = 21''$ and using a working stress of 16500 lbs. per sq. in.

$q = .88 \text{ sq. in.}$

Use $\frac{7}{8}''$ corrugated rounds 8" on centers, top and bottom.

DESIGN OF TOE.

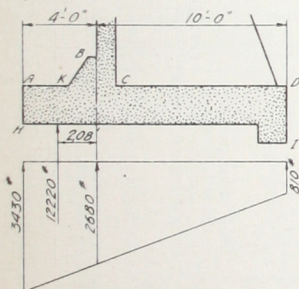

The bending moment in the base at the vertical plane through B , is:

$$12220 \times 2.08 \times 12 = 305000 \text{ in. lbs.}$$

If we neglect the fillet and take $d = 21''$, the amount of reinforcement required is 1.02 sq. in. per foot.

Use 1" corrugated rounds spaced 9" on centers; make $\frac{2}{3}$ of the bars 7'-0" long, and the remainder 13'-0" long.

Buttresses—The buttresses act as vertical beams attached to the base by the inclined reinforcing bars. The total stress in the steel necessary to anchor the buttress is obtained by dividing the overturning moment (due to the thrust of the earth above the plane $A-D$ on ten lineal feet of wall) by the lever arm of the steel, which may be taken as .86 *Or.*

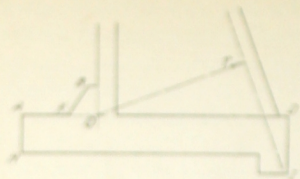

Figure 12.

From Table 1, page 146, the bending moment due to a fill of 23'-0" is 811133 inch lbs. per foot of wall; for one buttress the moment would be $10 \times 811133 = 8111330$ inch lbs. The area of metal required at an allowed stress of 16500 lbs. per square inch, would be :

$$A = \frac{8111330}{.86 \times .96 \times 16500} = 5.97 \text{ sq. in.}$$

This amount of reinforcement will not be required for the full height of the buttress; for example, the bending moment at a point 15'-0" below the top is 2250000 in. lbs., the A required is 2.03 sq. in.

Use 6-1/8" corrugated rounds, two of which extend to the top of the buttress, two to a point 5'-0" below the top, and two to a point 15'-0" below the top.

It is necessary to have some vertical reinforcement to transfer the load from the base plate to the buttress; this will be as shown on the detailed drawing.

The face wall should also be tied to the buttress by means of horizontal bars as shown. These bars should have sufficient area to transfer the horizontal thrust to the buttress without assistance from the concrete, and should be hooked over the horizontal bars in the face wall.

USEFUL INFORMATION.

COEFFICIENTS OF FRICTION.

The following table gives average values of the coefficients of friction. The values are subject to wide variation in individual cases:

Masonry on dry clay..... .50	Brick work on brick work. .5 to .7
Masonry on wet clay..... .33	Timber on timber2 to .5
Masonry on masonry..... .60	Timber on stone..... .4

ANGLE OF REPOSE, ϕ .

The natural slope of most materials used for filling purposes is roughly $1\frac{1}{2}$ to 1, corresponding to an angle of 34° with the horizontal. With wet sand ϕ may become as small as 15° .

WEIGHTS OF MATERIALS.

Pounds per Cubic Foot.

Sand, dry.....	90-110 lbs.
Sand, wet.....	110-120 lbs.
Earth, loose.....	75-90 lbs.
Earth, rammed.....	100 lbs.
Gravel.....	120-135 lbs.
Rock concrete.....	150 lbs.
Granite or lime stone masonry, well dressed.....	165 lbs.

INDEX, OCTOBER NUMBER.

	Page
Advantages of Reinforced Concrete Construction.....	143
Buttress Walls—Detailed Design.....	164
Cantilever Walls, Detailed Designs—	
Problem 1.....	153
Problem 2.....	159
Diagram of Forces Acting on a Retaining Wall—	
Surface of Fill Horizontal.....	148
Surface of Fill not Horizontal.....	149
Earth Pressure—Discussion.....	144
Earth Pressures, etc., Tables 1 and 2.....	146
Formulæ for Use in Designing.....	151
Notes on Design.....	147
Specifications for Materials.....	150
Useful Information.....	170

See page 37 (Bulletin No. 1) for Index on General Principles of Design, Building Construction.

See page 76 (Bulletin No. 2) for Index on Detailed Design of Typical Building and Complete Analysis of the Strength of Rectangular and T-shaped Beams.

See page 107 (Bulletin No. 3) for Index on Methods of Design and Standard Loadings for Highway Bridges.

See page 139 (Bulletin No. 4) for Index on Standard Designs for Bridges and Culverts for Highway Traffic.

